

# SP-MGTP

PORTABLE MULTI GAS DETECTOR WITH PUMP

## USER MANUAL

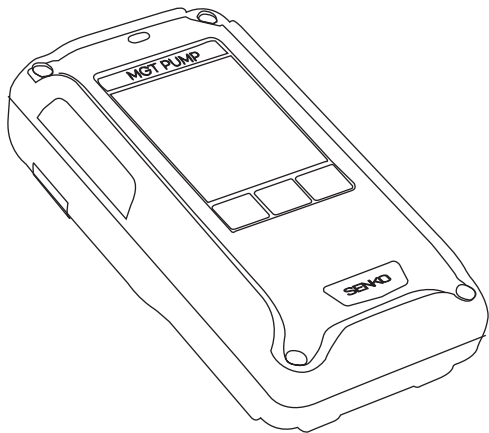

**SENKO**

[www.senko-detection.com](http://www.senko-detection.com)



# CONTENTS

<b>SAFETY WARNING</b>	4
<b>PRODUCT OVERVIEW</b>	
Product Introduction	6
Specification	6
LCD Display Symbols	7
<b>ACTIVATION</b>	
Switch On	8
Switch Off	8
<b>PUMP</b>	
Pump Test	9
Filter Replacement	9
Regulator	9
<b>DISPLAY</b>	
Measuring Mode	10
Display Mode	10
Battery Display	13
Alarm Display	14
<b>SETTING AND OPERATION</b>	
Alam Menu	16
Calibration Menu	17
Zero Calibration	17
Span Calibration	18
Test(Inspection) Menu	19
Set Menu	20
<b>LOG</b>	21
<b>CERTIFICATION</b>	22
<b>FAILURE / ESCAPE</b>	24
<b>TROUBLE-SHOOTING</b>	25
<b>MAINTENANCE AND REPLACEMENT</b>	
Charging	26
Gas Cylinder	26
Battery	26
Pump	26
Filter	27
Standard Accessories	27

# SAFETY WARNING



## WARNING

- Please do not replace or change any parts. Unauthorized replacement of parts and/or maintenance will invalidate the warranty.
- Please remove any debris on the surfaces of the sensor, LED or buzzer / pump hole before use.
- Test the performance of the gas sensor using bump test and using calibration gas regularly. The gas should trigger an alarm to be successful.
- Test whether the LED, alarm and vibration function properly on a regular basis.
- Using the device in conditions outside the certified temperature, humidity and pressure range may cause the instrument to malfunction or fail.
- The sensors inside the device may indicate the gas concentration differently according to the temperature, pressure and humidity they are in. Please make sure to calibrate the detector in the same environment in which it will be used.
- Extreme changes in temperature may cause drastic changes of the gas concentration. (e.g. using the detector where there is a huge gap between the inside and outside temperature) Please use the device when the concentration becomes stable.
- Severe pressure or impact may cause drastic changes of the gas concentration. Therefore, please use the device when the concentration is stable. Severe pressure or impact may cause also malfunction in the sensor or the device.
- The alarms are set according to the international standard and must be changed by an authorized expert.
- Charging or replacing the battery must be done in a safe area where there is no risk of explosion or fire. The use of spare parts not supplied by the manufacturer will invalidate the warranty.
- IR communication should only be done in a safe area where there is no risk of explosion or fire.
- Do not expose the detector to poisons such as alcohol and citrus based products, as poisons may damage device's accuracy and response time.
- If you suspect sensor poisoning, bump test and calibrate the instrument before further use.
- The detector is designed for use only in potentially explosive atmospheres where oxygen concentrations do not exceed 20.9% (v/v). Oxygen deficient atmospheres (<10% v/v) may suppress some sensor outputs.
- Recharge the battery before it is discharged.
- Charge the detector in temperature ranged from 0°C to 40°C
- The efficiency of the rechargeable battery decreases by approximately 20% after two years of normal use.
- Do not use any other charging adapter.
- Do not calibrate the device while or immediately after charging the battery.
- Do not calibrate if exposed to the condition representative of the IP rating.

- Do not perform the calibration during the stabilization process after turning on the device.
- Sudden changes in atmospheric pressure may cause oxygen concentration to vary temporarily.
- Before daily use, check the pump port is clear of any obstructions, debris, or blockage.
- If the pump port is blocked by any pollutants, the measured reading may be measured lower than the actual concentration.
- The equipment shall only be carried and must not be laid down unattended.
- If a charge-generating mechanism is present, the exposed metallic part on the enclosure is capable of storing a level of electrostatic charge that could ignite IIC gases. Therefore, the user / installer shall implement precautions, for example, those listed above, to prevent the build-up of electrostatic charge. This is particularly important if the equipment is being used in a Zone 0 environment.
- The equipment shall only be charged while in the non-hazardous area, using a charger specifically supplied for use with the unit (for example part number ICP12-060-1200D, manufactured by Shenzhen Shi Ying Yuan Electronics Co, LTD), approved as SELV or Class 2 equipment against IEC 60950, IEC 61010-1 or an equivalent IEC standard. The maximum voltage and current from the charger shall not exceed 6.3 Vdc plus tolerances and 1.2 A respectively and shall be further limited by the charging system to  $U_m = 6.3$  Vdc. The ambient temperature during charging shall be in the range 0 °C to 40 °C.
- The battery and sensors should only be replaced by SENKO authorized service providers in a safe zone, free of hazardous gases.



## CAUTION

- Please read the manual carefully.
- The device is not a gas analyser, but a gas detector designed to detect the presence of a gas.
- If the instrument fails to pass calibration, stop using and consult the manufacturer.
- Test the device every 30 days under the atmospheric environment of clean air without gases.
- To clean the exterior of the device use only a soft cloth and do not use chemical detergents.



## REFERENCE

- For flammable gas equipment installation, operation and maintenance information, please refer IEC 60079-29-2
- Conversion for %LEL and %vol follows the ANSI/NFPA 497 standard.

# PRODUCT OVERVIEW

## PRODUCT INTRODUCTION

The SP-MGTP(Pump) is a sampling type gas detector that measures six(6) major gases simultaneously, which cause most of the industrial accidents, to protect workers from the disasters caused by the Oxygen deficiency, Toxic gas poisoning and gas explosion. It detect up to 6 gases with 37 different toxic and flammable gas combinations and displays their concentrations and raises an alarm(visual, vibrating, and audible) when the risk occurs.





The detector with a pellistor sensor(LEL) will operate continuously for more than 30 hours when fully charged. The detector with an NDIR sensor(LEL, CO2) will operate continuously for around 5 days when fully charged under normal operating conditions.

## SPECIFICATION

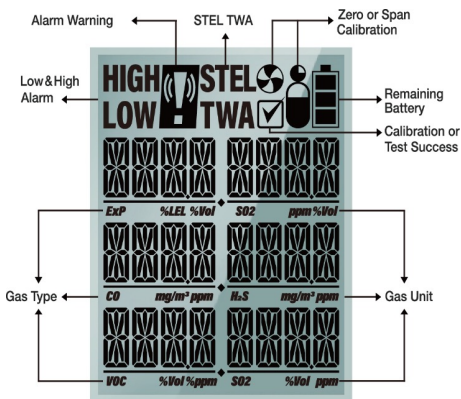
<b>Model Name</b>	SP-MGTP (Pump)
<b>Sensor Type</b>	Electrochemical for toxic gases and O2 / PID for VOCs gas / Catalytic and NDIR for combustible gases
<b>Measuring Type</b>	Sampling Type (Built-in Pump)
<b>Display</b>	Segment LCD Display, LCD Backlight, Indicator LED
<b>Button</b>	3 Operation and Programming Keys
<b>Dimension</b>	77(W) x 146(H) x 43(D) mm
<b>Weight</b>	490g
<b>Operating Temperature</b>	-20°C to +50°C
<b>Operating Humidity</b>	10% to 90% RH (Non-condensing)
<b>Alarm</b>	Visual : LCD Alarm Display, LCD Backlight Indicator LED Audible/ Buzzer (90dB at 10cm)
<b>Data Saving</b>	Event Log : 30 EA, Calibration Log : 30 EA Bump Log : 30EA, Data log Two Months or longer
<b>How to Fix</b>	Belt Clip
<b>IP</b>	IP 67
<b>Pressure</b>	80 ~ 120 KPa
<b>Battery Type</b>	Rechargeable Lithium-Ion Nominal Voltage : 3.7V, Nominal Capacity: 4000mAh Max Charging Voltage: 6.3V
<b>Case</b>	TPU covered Poly Carbonate(PC)
<b>Options</b>	IR-Link
<b>Flow Rate</b>	250 ~ 300 cc
<b>Storage Condition</b>	
<b>Temperature</b>	0°C to 20°C
<b>Humidity</b>	15% to 90% RH (Non-condensing)
<b>Pressure</b>	90 ~ 110 Kpa
<b>Shelf life</b>	6 months

## LCD DISPLAY SYMBOLS



Icon	Name	Description
<b>LOW</b>	Low Alarm	Low(1st) Alarm
<b>HIGH</b>	High Alarm	High(2nd) Alarm
	Alarm Warning	Alarm Condition
<b>STEL</b>	STEL	STEL Alarm
<b>TWA</b>	TWA	TWA Alarm
	Zero Calibration	Fresh Air Calibration
	Calibration or Test Success	Device Stabilization, Configuration View, Calibration Succeeded
	Span Calibration	Standard Gas Calibration
	Battery	Remaining Battery

# ACTIVATION

## SWITCH ON

Press the power button for 2 seconds and SYS boot is displayed. Once the device turns on, the version and LCD are displayed. After 10 seconds of system test, the warmup will begin.

If errors occur during system test, the device will indicate error code. (Regarding error code, please refer to the Chapter 8(Failure and Escape).

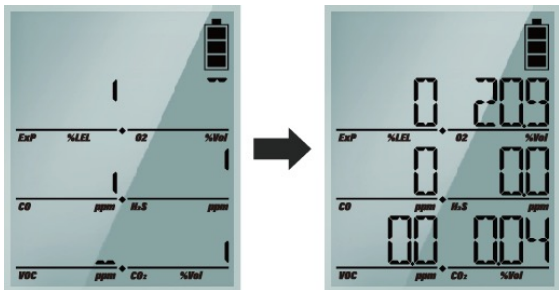

The exact warmup time differs depending on which sensor types are fitted. After completing the warmup, the device goes into the measurement mode.

### CAUTION

To check the gas response performance of the sensor, it is recommended to do a bump test with gas concentration higher than the alarm set point. It is recommended to do a bump test before each use of the device. Users are required to check if the device is working properly and ensure the pump port is clear of any obstructions, debris, or blockage.

## SWITCH OFF

To switch off, press and hold down the enter button for three seconds. The display counts down three seconds with the "SYS OFF" message.

(The device will not be switched off only unless you keep pressing the button for longer than three seconds.)



# PUMP

## PUMP TEST

When you change the gas tube or reconnect to the detector, test the sampling system by blocking the end of the tube. When the flow is blocked, the device will alarm every second. If no alarm activates this indicates a leak in the system or a failure of the pump.

## FILTER REPLACEMENT

The gas inlet is protected by the particulate filter and membrane filter. When the filter is blocked, the sampling system will be unable to work and the warning alarm will be activated sounding every second.

Visually inspect the filter to ensure the filter is free of debris or obstructions. Discolouration of the filter is the best indicator that the filter needs replacing. If the filter needs to be replaced, loosen the two screws and replace with new filters. After replacing with new filter, reassemble the screws and continue to use it.

## REGULATOR

The detector has an internal pump drawing the gas, so when performing a calibration or bump test, a demand flow regulator should be used on the gas cylinder.

# BATTERY DURATION

Category	Gas	Operating Time
P0 Type : PID, LEL(Catalytic-CH4)	O2 + Toxic + LEL(Catalytic) + PID	≥20h
	O2 + Toxic + LEL(Catalytic)	≥24h
N0 Type : PID, LEL(IR-CH4)	O2 + Toxic + LEL(IR) + PID	≥57h
	O2 + Toxic + LEL(IR)	≥72h
N1 Type : PID, LEL(IR-CH4)	O2 + Toxic + LEL(IR) + PID	≥40h
	O2 + Toxic + LEL(IR)	≥52h
N2 Type : PID, LEL(IR-CH4/CO2)	O2 + Toxic + LEL(IR) + CO2(IR) + PID	≥40h
	O2 + Toxic + LEL(IR) + CO2(IR)	≥52h
00 Type : PID	O2 + Toxic + PID	≥57h
	O2 + Toxic	≥72h

# DISPLAY

## MEASURING MODE

After stabilization the device goes into the normal measuring mode. The gas concentration and the battery power level are displayed on the LCD display. Oxygen is displayed in %vol, combustible gases in %LEL and H<sub>2</sub>S, CO in PPM (parts per million).

When the gas concentration levels change, the value is displayed in real time, and when the levels exceed the threshold for either LOW alarm or HIGH alarm (or TWA/STEL), the display icons of **LOW**, **HIGH**, **TWA** or **STEL** flash regularly and the audible, visual and vibration alarms activate.

When the concentration detected by the device returns below the alarm threshold, the alarms stop, however the alarm icon continues to indicate that an alarm has occurred until the Enter button is pressed to accept it.



## DISPLAY MODE

Pressing the  $\Delta$  or  $\nabla$  button steps the display through fourteen different display modes as shown above.

### LCD Display

### Details

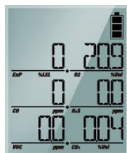

#### Measuring Mode (Basic Display)

Display the current gas levels of the atmosphere and the battery power level.

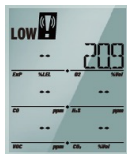

#### Measure Value (Min)

A low gas alarm has been triggered.

\*In an ambient air, the Oxygen level normally indicates 20.9%vol.



#### Measure Value (Max)

A high gas alarm has been triggered.

\*In an ambient air, the Oxygen level normally indicates 20.9%vol.



### Measuring Mode (STEL)

A STEL (Short Term Exposure Limit) gas alarm has been triggered indicating the 15 minutes average exposure has been exceeded.



### Measure Value (TWA)

A TWA (Time weighted average) gas alarm has been triggered indicating the 8 hours average exposure has been exceeded.

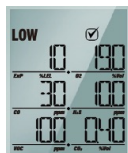

### Alarm Value (1st/Low Alarm)

Display the preset low alarm levels.



### Alarm Value (2nd/High Alarm)

Display the preset high alarm levels.



### Alarm Value (STEL)

Display the preset STEL levels.

# DISPLAY

## LCD Display

## Details



### Alarm Value (TWA)

Display the preset TWA levels.



### Version / Battery / Temperature

Firmware Version, Current battery voltage, Current temperature(Celsius)



### Date / Time



### Calibration Concentration Value

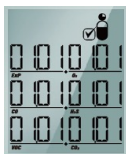

### Last Calibration Date

01.01 = January 1st (mm dd)

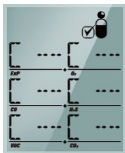
**Cal Remain Day**

Remaining time to next calibration date when the calibration interval is configured. (Default: N/A)

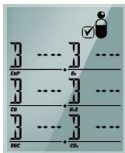
**Bump Remain Day**

Remaining time to next bump test date when the bump interval is configured. (Default : N/A)

## BATTERY DISPLAY

The battery status is indicated by three icons: High, Medium, Low.

**Low:** When the battery icon indicates "low", the detector will activate alarm every three minutes. When the low battery point is reached, the detector will continue to operate for about 30 minutes.

**End:** When the battery icon indicates "end", the detector will display "SYS L-Bat" for two seconds and then it will turn off.

















To charge the detector, plug in the charging adapter. During charging, the battery indicator will circulate.

### WARNING

- Do not charge the battery in an explosive atmosphere.
- Do not charge the device at temperatures higher or lower than the range of 0°C to 40°C.
- Use only the charging adapter provided by SENKO for charging the battery.
- Charging the battery after the device fully turned off is recommended.

# DISPLAY

## ALARM DISPLAY

Type	Trigger Condition	LCD Display	Alarm Sound
Low Alarm	Exceed LOW alarm value	 LOW icon & gas concentration levels displayed	 BUZZER, LED  Vibration
High Alarm	Exceed HIGH alarm value	 HIGH LOW icon & gas concentration levels displayed	 BUZZER, LED  Vibration
TWA Alarm	Exceed TWA alarm value	 TWA icon & gas concentration levels displayed	 BUZZER, LED  Vibration
STEL Alarm	Exceed STEL alarm value	 STEL icon & gas concentration levels displayed	 BUZZER, LED  Vibration
Bump Test	A bump test is now due to be performed	Bump Display "bump" blinking	Stops after Bump Test is completed successfully
Execute Calibration	A calibration is now due to be performed	 icon & Gas Title Blinking	Stops after Calibration is completed successfully
Over Limit	Exceeding the overrange Limit for a sensor	 OL OL OL OL	 BUZZER, LED  Vibration
Under Limit	Sensor is reading a below Zero value	 UL	Stops after Zero Calibration

**LOW Alarm / HIGH Alarm activation:** In the event of a High Alarm the user must leave the area immediately. The audible, visual and vibration alarms stop when the device is in a safe area where the gas concentration is normal.

**TWA Alarm activation:** The alarm activates when the average gas levels for the last eight hours exceed the TWA concentration. The audible, visual and vibration alarms stop when the device is in a safe area where the gas concentration is normal.

**STEL Alarm activation:** The alarm activates when the average gas levels for the fifteen minutes exceed the STEL concentration. The audible, visual and vibration alarms stop when the device is in a safe area where the gas concentration is normal.

**Over Limit:** When the detector is exposed to gas concentrations above the upper limit range, it will display OVL (Over Limit) alarm on the display.

**Under Limit:** When the detector indicates a below zero value, it will display UL(Under Limit) & Zero calibration warning on the display. The alarm will clear when a successful zero calibration is performed.

#### NOTE

- If a gas alarm occurs, evacuate to a safe place, you should take appropriate action.
- The factory setting for gas alarms is non-latching. Latching alarms can be set up by using IR-LINK (option) in computer.
- Description of any suppression of indication can be changed using IR-LINK(option) in computer. (I don't understand what this is supposed to mean, I would suggest removing it)

Category	Details
Bump Test Interval	Notices the user on a regular basis to check the device.
Calibration Interval	Notices the user on a regular basis to calibrate the sensor.
Self-Test Interval	Notices the user on a regular basis to Self-Test

\* SENKO IR-LINK Options

# SETTING AND OPERATION

When pressing and holding  $\Delta$  +  $\nabla$  buttons for two seconds simultaneously, the detector will enter into the setting mode. In the setting menu, the Alarm Menu, Calibration Menu, Test(Inspection) Menu, and Set Menu will display and users can configure the setting by scrolling to the required menu and pressing the power button in a menu.

In Setting Mode, the display will return to the measurement mode after the 10 seconds of inactivity.

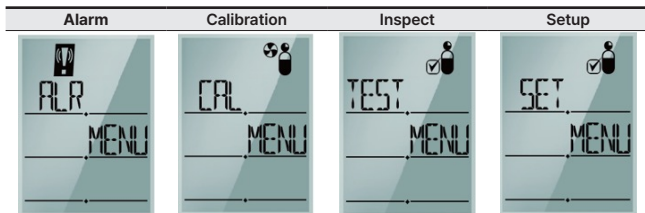

## ALARM MENU

In the alarm menu, press the power button and the device will enter the alarm setting mode. In the alarm setting mode (ALR SET), pressing the  $\Delta$  or  $\nabla$  button, steps through four menus as below and the user can enter and change or clear the previous MIN, MAX, TWA, and STEL alarms by pressing the power button.

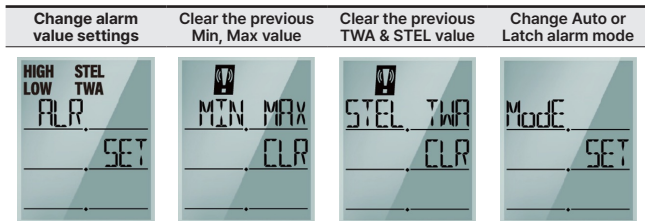



Category	Details
ALR SET	Low, High, STEL, TWA
MIN MAX CLR	Deletes the previously measured MAX and MIN levels.
STEL TWA CLR	Deletes the previously measured STEL and TWA levels.
ModE SET	Sets the alarm to Latch (where the device stays in alarm when a gas alarm is triggered until the button is pressed to accept it) or Auto where the alarm stops when the reading returns to normal levels.



## CALIBRATION MENU

In the calibration menu, when the power button is pressed, the zero and span calibration will be displayed. Select the calibration mode (Zero or Span) by pressing  $\Delta$  or  $\nabla$  button and power button to enter the mode.

Zero Calibration Function	Span Calibration Function
	

To activate zero or calibration, press the power button.

- Zero Run :  
Zero Calibration (Fresh Air Calibration)
- SPAN Run :  
Span Calibration (Standard Gas Calibration)

In the Span calibration mode, select a sensor to be calibrated by pressing on/off.

### NOTE

- If the sensitivity of each sensor has drifted below the standard accuracy, the calibration will fail.
- If the detector is dropped or damaged, if any of the sensors are changed, or if the device fails a bump test, a calibration must be performed.

## ZERO CALIBRATION (FRESH AIR CALIBRATION)

In the zero run mode, when pressing the power, the ON/OFF will be displayed. By pressing  $\Delta$  or  $\nabla$ , move the sensor to be calibrated and select on or off. When you press the power button for three seconds, the zero calibration will be performed with 10 seconds countdown. To abort the calibration, press the power button. If the calibration fails, "FA" will be displayed. When the calibration fails continuously, stop using the detector and contact the manufacturer or authorized agents for either sensor replacement or warranty.

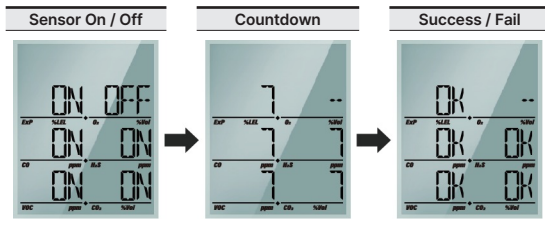

# SETTING AND OPERATION

## SPAN CALIBRATION (STANDARD GAS CALIBRATION)

After selecting a sensor in calibration mode, connect the tube as shown on the right.

Ensure the tube is connected properly and check the cylinder matches with the calibration setting levels.



### CAUTION

- Before calibration, check the sensor warmup is completed. The device will display the normal concentration when the warmup is complete. If normal concentrations are not being displayed, it indicates the warmup is not complete and the calibration should not be performed.
- The calibration should be performed in a clean air environment, free of hazardous gases and the hose length should be no longer than 0.9m.

### IMPORTANT

As to a span calibration, if VOC(PID) sensor is included, perform the span calibration of PID(VOC) sensor after other sensors are calibrated.

In the "SPAn RUN" mode, when you press the power button, the ON/OFF will be displayed for each sensor.

Press the  $\Delta$  or  $\nabla$  button to select a sensor to be calibrated and the power button to select either on or off, and then press the power button for three seconds to activate the calibration. The normal countdown takes 90~180 seconds and each sensor has different calibration time. To abort the calibration, press the power button. If the calibration fails, the failed gas will flash.

If the calibration continues to fail, contact SENKO or authorized agents to check either sensor replacements or warranty.

### CAUTION

- The initial calibration is completed at SENKO CO. Ltd. before the device is delivered. The calibration values are saved in the device. Calibration using gas levels which are not the same as the saved calibration value will impair the accuracy of the device performance. Normally, the calibration should be done once a year after the purchase and regularly every six months thereafter.
- The device is calibrated on the assumption that oxygen concentration is 20.9%vol, the combustible gas is 0%LEL, and the toxic is 0ppm in a clean air atmosphere, fresh air calibration must be conducted in the same clean air without the presence of any other gases. Fresh air calibration in the airtight spaces therefore is not recommended. Make sure to there is adequate ventilation for the exhaust gases.

## TEST(INSPECTION) MENU

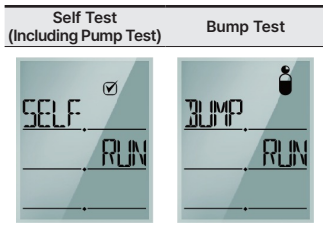

In the test menu, when pressing the power button, the self-test and bump test mode will be displayed.

In the SELF RUN mode, press the  $\Delta$  or  $\nabla$ , and then select the desired function to test (LCD  $\rightarrow$  Buzzer  $\rightarrow$  LED  $\rightarrow$  Backlight Yellow  $\rightarrow$  Backlight Red  $\rightarrow$  Motor  $\rightarrow$  Memory) and press the power button to activate the test.

In the BUMP RUN mode, press the power button to enter the mode, and then select the either on or off for each sensor. Attached the tube and apply the gas once the countdown starts. If the test passes, "OK" will be displayed. If the test fails, "FA" message will be displayed and the bump test message will flash in the measurement mode.

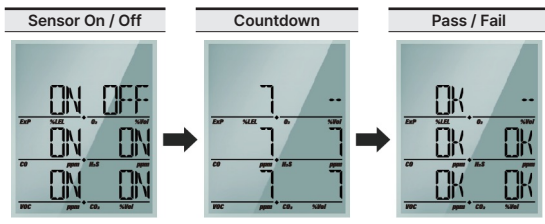

### IMPORTANT









Ensure that all sensors are warmed up before performing the bump test. It will take some time to warm up the sensors. You can distinguish the sensor warm up by looking at the sensor readings. If the detector is not warmed up, the last segment will be blinking.

\* When you perform the bump test, make sure to use the high concentration gas than 1st alarm level.

# SETTING AND OPERATION

## SET MENU

In the "set menu", press the power button to enter into the mode, and then select from the four menus below by pressing  $\Delta$  or  $\nabla$  button. To enter the mode, press the power button.

Back Light On/Off	LED On/Off	Buzzer On/Off	Vibration On/Off
			
Pump Low/Mid/High	Response LEL Factor 0.00 ~ 99.99	Response VOC Factor 0.00 ~ 99.99	Setting Initialize
			

Category	Details
BL SET	Blacklight ON / OFF Setting
LED SET	LED ON / OFF Setting
BUZ SET	Buzzer ON / OFF Setting
Mot SET	Motor ON / OFF Setting
PUMP SET	Pump Low/Mid/High Setting
RSPF LEL SET	Response LEL factor 0.00~99.99 Setting (Only when LEL Sensor operating)
RSPF VOCs SET	Response VOCs factor 0.00~99.99 Setting (Only when VOCs sensor operating)
INIT SET	Setting initialize

# LOG

During a normal operation, data, event, calibration, and bump logs are stored in the device. The stored data can be downloaded via SENKO IR LINK with the PC program.

Up to 30 log events will be saved, and once the data is full, the oldest date will be overwritten automatically and the new data will be stored. (First in-First out). The detector will save a data log every one minute in clean air without hazardous gases. In the event of gas alarms or configuration changes, the data log will be saved every one second.



Type	Condition Trigger
EVENT Alarm (High, Low, TWA, STEL)	Occurrence time, Duration, Alarm Type, Gas Concentration, Serial Number.
BUMP TEST Log	Test date, Pass/non-pass, Calibration Gas Concentration, Detected Concentration.
Calibration Log	Date of the Calibration, Type, Calibration Gas Concentration, Detected Concentration.
Data Log	Time, Date of executing IR-LINK, Concentration, Alarm Types, Options.

# CERTIFICATION

## √ FCC compliance

This device is tested according to FCC rules part 15 and complies with restrictions for a CLASS A digital device.

These restrictions are designed to provide adequate protection against an industrial environment which may cause harmful interference during operation. This device generates, uses, and can radiate radio frequency energy and, if the instruction manual is not followed correctly for installation or usage, it may cause interference to wireless communications.

		Certifications	Standards
IECEX	IECEX CSA 23.0016X	SP-MGTP-P0 Series Ex da ia IIC T4 Ga or Ex da ia IIB T4 Ga	IEC60079-0: 2017 Ed. 7 IEC60079-1: 2014-06 Ed.7 IEC60079-11: 2011 Ed. 6
		SP-MGTP-00/N0 Series Ex ia IIC T4 Ga or Ex ia IIB T4 Ga	
		SP-MGTP-N1/N2 Series Ex db ia IIC T4 Gb or Ex db ia IIB T4 Gb	
KCs	KTL 23-KA2BO -0353X  KTL 23-KA2BO -0354X  KTL 23-KA2BO -0355X	SP-MGTP-N0 Series Ex ia IIC T4 Ga	IEC60079-0: 2017 Ed. 7 IEC60079-1: 2014-06 Ed.7 IEC60079-11: 2011 Ed. 6
		SP-MGTP-N2 Series Ex db ia IIC T4 Gb	
		SP-MGTP-P0 Series Ex da ia IIC T4 Ga	
ATEX	CSANe 23ATEX1128X   0080   II 1G, II 2G	SP-MGTP-P0 Series Ex da ia IIC T4 Ga Ex da ia IIB T4 Ga	EN IEC 60079-0:2018 EN 60079-1:2014 EN 60079-11:2012
		SP-MGTP-00/N0 Series Ex ia IIC T4 Ga Ex ia IIB T4 Ga	
		SP-MGTP-N1/N2 Series Ex db ia IIC T4 Gb Ex db ia IIB T4 Gb	
UL/CSA	LC24 CA22331-1	SP-MGTP-P0 Series "Ex da ia IIC T4 Ga Class I, Division 1, Groups A, B, C, and/or D, T4 Class I, Zone 0, AEx da ia IIC T4 Ga" "Ex da ia IIB T4 Ga Class I, Division 1, Groups C, and/or D, T4 Class I, Zone 0, AEx da ia IIB T4 Ga"	CSA C22.2 No. 60079-0:2019 /UL 60079-0- Edition 7 CSA C22.2 No. 60079-1:16(R2021) /UL 60079-1 - Edition 7 CSA C22.2
		SP-MGTP-00/N0 Series "Ex ia IIC T4 Ga Class I, Division 1, Groups A, B, C, and/or D, T4 Class I, Zone 0, AEx ia IIC T4 Ga" "Ex ia IIB T4 Ga Class I, Division 1, Groups C, and/or D, T4 Class I, Zone 0, AEx ia IIB T4 Ga"	No. 60079-11:14(R2023) /UL 60079-11 - Edition 6 UL 913 - Edition 8 CAN/CSA-C22.2 No. 61010-1-12 (R2022) /UL 61010-1 - Edition 3
		SP-MGTP-N1/N2 Series "Ex db ia IIC T4 Gb Class I, Division 1, Groups A, B, C, and/or D, T4 Class I, Zone 1, AEx db ia IIC T4 Gb" "Ex db ia IIB T4 Gb Class I, Division 1, Groups C, and/or D, T4 Class I, Zone 1, AEx db ia IIB T4 Gb"	

		<b>Certifications</b>	<b>Standards</b>
<b>INMETRO</b>	BRA 23. GE0011X	SP-MGTP-P0 Series Ex da ia IIC T4 Ga or Ex da ia IIB T4 Ga	ABNT NBR ISO IEC 60079-0:2020 ABNT NBR IEC 60079-1:2016
		SP-MGTP-00/N0 Series Ex ia IIC T4 Ga or Ex ia IIB T4 Ga	ABNT NBR IEC 60079-11:2013
		SP-MGTP-N1/N2 Series Ex db ia IIC T4 Gb or Ex db ia IIB T4 Gb	
<b>CNEx</b>	CNEx24. 2987X	SP-MGTP-P0 Series Ex da ia IIC T4 Ga Ex da ia IIB T4 Ga	
		SP-MGTP-00/N0 Series Ex ia IIC T4 Ga Ex ia IIB T4 Ga	
		SP-MGTP-N1/N2 Series Ex db ia IIC T4 Gb Ex db ia IIB T4 Gb	
<b>EMC</b>	Direct 2014/30/EU		

# FAILURE / ESCAPE

If the detector is not working properly, the detector will display the following error codes on the LCD.

Code	Description	Solution
Err - 1	Pump Operation Error	Check if the pump and filter is dirty. If it is then replace with new pump inlet and/or filters, and turn the detector off and on.
Err - 2	Memory Error	Memory access Error, Power OFF → ON
Err - 3	Sensor Error	Sensor Operation Error, Power OFF → ON
Err - 4	IR Sensor Error (Mipex LEL)	Sensor Operation Error, Power OFF → ON
Err - 5	IR Sensor Error (Dynamment LEL or CO2)	Sensor Operation Error, Power OFF → ON
Err - 6	IRDA Communication Error	IRDA Communication Error, Power OFF → ON
Err - 7	PID Power removed	PID Sensor Operation Error, Power OFF→ON, Contact with Manufacturer
Err - 8	PID Oscillator overloaded	PID Sensor Operation Error, Power OFF→ON, Replace the PID Sensor
Err - 9	PID Oscillator not working	PID Sensor Operation Error, Power OFF→ON, Replace the PID Sensor
Err - 10	PID Lamp not illuminated	PID Sensor Operation Error, Power OFF→ON, Lamp Cleaning

If the error code is not solved after switching off and on the detector, please contact SENKO or authorized manufacturer. I am not sure if there is a missing "not" in here, I assume if the error code is solved then the user continues to use the device, so only contacts Senko if the code is not solved.

If pump operation fails, it will activate an alarm every minute continuously until the detector is turned off.



# TROUBLE-SHOOTING

<b>Problem</b>	<b>Possible Cause</b>	<b>Trouble-shooting</b>
Device will not Power on	Fully discharged or no battery	Re-use after charging sufficiently
"ERR" on the LCD	Device is in error	Re-start or Change the sensor (Fix the error)
Can't measure Gas precisely	Needs calibration or decontamination of sensor filter	Conduct calibration or Change, clean sensor filter. (Particulate & Syringe filter)
Alarm on with no reason	Needs calibration or there is a Device error	Conduct calibration or Change sensor
Calibration fail	Setting error or there is a Device error	Change sensor or Conduct calibration after setting .
Battery will not charge	Charger error or there is a Device error	Change battery or Check charger connection
Continuous charging, device will not charge to 100%	Charging battery	Turn off the power before charging the device

# MAINTENANCE AND REPLACEMENT

## CHARGING

Only the charging adaptor supplied by SENKO should be used and the instructions below for charging must be followed.



### CAUTION

- Charge at room temperature (0°C to 40°C)
- Ensure the charging adaptor is firmly connected to SP-MGTP
- The backlight indicates charging is taking place by switching On/Off every 1 second
- Do not use any alternative adaptor

## GAS CYLINDER

Before use a gas cylinder, check the expiration date and if the expiration date has passed, do not use the cylinder. When you use cylinder, ensure to connect the demand flow regulator to the cylinder.

## BATTERY

Charge the battery only with the supplied charging adaptor from SENKO. Charging should be carried out in the temperature range 0°C to 40°C.

## PUMP

When you change the tube or reconnect it to the detector, the pump test should be performed by blocking the end of tube. If the flow is blocked, the alarm will be sound every second.

## FILTER

Ensure the filter is free of debris or obstructions by looking at the colour. If the filter needs to be replaced, loosen the two screws and replace with new filters. After replacing with new filter, reassemble the screws and continue to use it.

The gas inlet is protected by the particulate filter and Syringe filter. When the filter is blocked, the sampling system is unable to work and the warning alarm will sound every second.

## STANDARD ACCESSORIES

The standard accessories below are all included in the box.

Quick Disconnect  
& 1m tube



Charger



Dust Filter &  
PTFE Filter

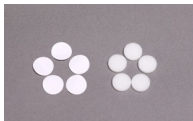

# LIMITED WARRANTY

SENKO warrants this product to be free of defects in workmanship and materials-under normal use and service-for two years from the date of purchase from the manufacturer or from the product's authorized reseller.

The manufacturer is not liable (under this warranty) if its testing and examination disclose that the alleged defect in the product does not exist or was caused by the purchaser's (or any third party's) misuse, neglect, or improper installation, testing, or calibrations. Any unauthorized attempt to repair or modify the product, or any other cause of damage beyond the range of the intended use, including damage by fire, lightning, water damage or other hazard, voids liability of the manufacturer.

In the event that a product should fail to perform up to the manufacturer's specifications during the applicable warranty period, please contact the product's authorized reseller or SENKO service centre at +82-31-492-0445 to get repair/return information.

# SENKO

**SENKO Co., Ltd.** [www.senko-detection.com](http://www.senko-detection.com)

T. +82-31-492-0445 | F. +82-31-492-0446 | E. [sales@senko.co.kr](mailto:sales@senko.co.kr)  
445, Doksanseong-ro, Osan-si, Gyeonggi-do, 18111, Republic of Korea